

# 六角ブローチホルダ

## Broach Tool Holder

- 六角穴加工用工具  
For broaching (hexagonal hole)
- 旋盤、マシニングセンタ用  
For Lathe and Machining Center

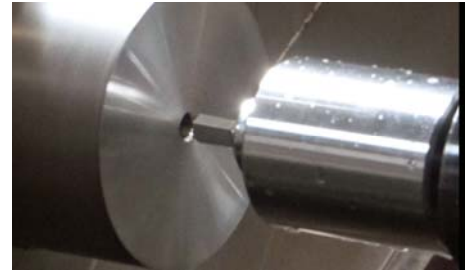

旋盤使用例  
(Lathe)



マシニング使用例  
(Machining Center)

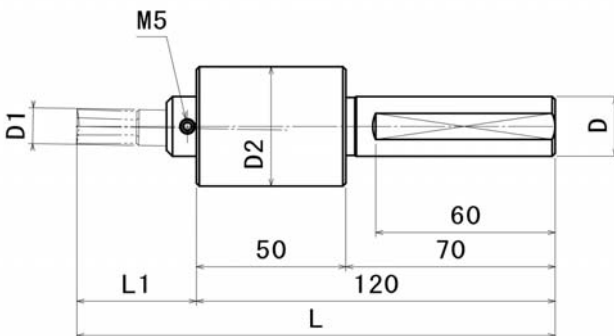

六角穴加工例  
(Hexagonal hole)



### 旋盤用 (for Lathe)

CODE	D	D1	D2	L	L1
ST19.05-BAH8L-130	19.05	8	40	145.2	15.2
ST19.05-BAH12L-130		12		160	30
ST20-BAH8L-130	20	8		145.2	15.2
ST20-BAH12L-130		12		160	30

### マシニングセンタ用 (for Machining Center)

CODE	D	D1	D2	L	L1
ST20-BAH8M-160	20	8	50	160	40
ST20-BAH12M-160		12			

【デモ動画↓】



## ブローチカッター(超硬)

Broach Cutter (Carbide)

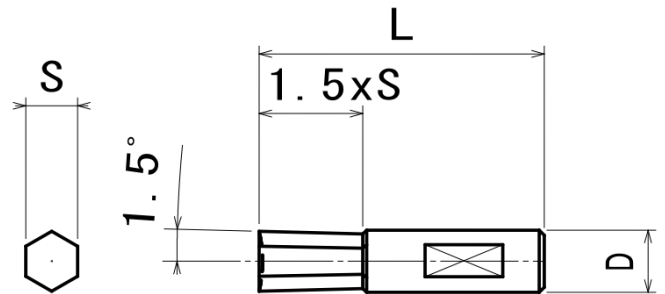

CODE	S対辺(mm)	D柄径(φ)	L全長(mm)
ST8-3C	3 +0.1/+0.2	8 h6	28.2 ± 0.1
ST8-4C	4 +0.1/+0.2		
ST8-5C	5 +0.1/+0.2		
ST8-6C	6 +0.1/+0.2		
ST8-7C	7 +0.1/+0.2		
ST8-8C	8 +0.1/+0.2		
ST8-9C	9 +0.1/+0.2		
ST8-10C	10 +0.1/+0.2		
ST8-11C	11 +0.1/+0.2		
ST8-12C	12 +0.1/+0.2		
ST8-13C	13 +0.1/+0.2		
ST8-14C	14 +0.1/+0.2		

CODE	S対辺(mm)	D柄径(φ)	L全長(mm)
ST12-6C	6 +0.1/+0.2	12 h6	55 ± 0.1
ST12-7C	7 +0.1/+0.2		
ST12-8C	8 +0.1/+0.2		
ST12-9C	9 +0.1/+0.2		
ST12-10C	10 +0.1/+0.2		
ST12-11C	11 +0.1/+0.2		
ST12-12C	12 +0.1/+0.2		
ST12-13C	13 +0.1/+0.2		
ST12-14C	14 +0.1/+0.2		
ST12-15C	15 +0.1/+0.2		
ST12-16C	16 +0.1/+0.2		
ST12-17C	17 +0.1/+0.2		
ST12-18C	18 +0.1/+0.2		
ST12-19C	19 +0.1/+0.2		

