



HMA-SCA メタルソークランプボルト

METAL SAW CLAMPING BOLT



特長 Features

- ◆ヘッドマスターアーバ専用締付ボルトで各種メタルソーの厚み(3mmまで)に対応。
Metal saw up to 3mm thickness can be mounted by special mounting bolt.
- ◆専用薄ボルト仕様で先端部の干渉が軽減され加工能率がUPいたします。
Less interference thanks to special thin head bolt.

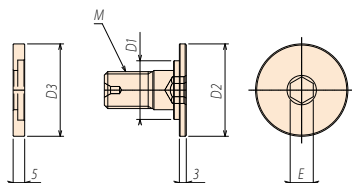
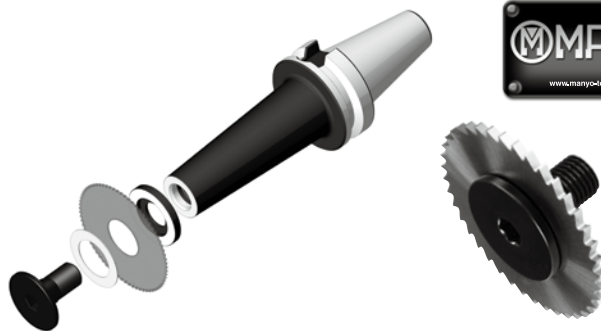

(METAL SAW CLAMPING BOLT)

適用スロット

適用ホルダ

CODE	D1	D2	D3	M	E	SLOT	Holder
HMA 8 -SCA12	12	16.5	20	M 8	5	MSSH-32	BT,HSK,ST-HMA 8
HMA10-SCA13	13	21	24	M10	6	MSSH-40	BT,HSK,ST-HMA10
HMA12-SCA15.875	15.875	26	26	M12	8	MSSH-50	BT,HSK,ST-HMA12
HMA16-SCA25.4	25.4	40	40	M16	10	-	BT,HSK,ST-HMA16
HMA16-SCA31.75	31.75	46	46				

- 特殊サイズも注文により製作いたします。Special size is available upon request.
- ヘッドマスターアーバは、P22,23をご参照ください。See P22,23 for Head master arbor.
- メタルソーカッターは付属しておりません。Not include metal saw cutter.

MSSH モジュラースロットカッタ

MODULAR SLOT CUTTER

特長 Features

- ◆ヘッドマスターアーバに取付け交換が出来コスト軽減。
Using with HMA arbors helps cost reduction.
- ◆先端取付部の干渉が無く加工効率がUPいたします。
Processing efficiency is improved thanks to no interference in nose portion.
- ◆ソリッドヘッドで再研磨可能エコで経済的。
Solid head can be regrinded.
- ◆ロー付タイプのカッタと比較して高剛性、ビビリ発生が軽減。
Higher rigidity and better surface finish than brazing type cutter.
- ◆切粉排出性が非常に高い新開発刃先形状。
Newly developed tool edge design with very high cutting chip discharging.
- ◆高耐熱・高硬度の専用コーティングの採用で高寿命加工能率が大幅UPいたします。
Processing efficiency is drastically improved thanks to special coating long life cutter with high heat resistance and hardness.



(MODULAR SLOT CUTTER-SH)

(No.of Teeth)

適用ボルト

CODE	D	T	d	W	刃数	適用ボルト
MSSH-32-15	32	1.5	12	3	6	HMA 8 -SCA12
-20		2.0				
-25		2.5				
-30		3.0				
MSSH-40-20	40	2.0	13	4.5	6	HMA10-SCA13
-25		2.5				
-30		3.0				
-40		4.0				
MSSH-50-20	50	2.0	15.875	6	8	HMA12-SCA15.875
-25		2.5				
-30		3.0				
-40		4.0				

(MODULAR SLOT CUTTER-RH)

(No.of Teeth)

適用ボルト

CODE	D	T	d	W	刃数	適用ボルト
MSRH-32-0.75R	32	1.5	12	3	6	HMA 8 -SCA12
-1.0R		2.0				
-1.25R		2.5				
-1.5R		3.0				
MSRH-40-1.0R	40	2.0	13	4.5	6	HMA10-SCA13
-1.25R		2.5				
-1.5R		3.0				
-2.0R		4.0				
MSRH-50-1.0R	50	2.0	15.875	6	8	HMA12-SCA15.875
-1.25R		2.5				
-1.5R		3.0				
-2.0R		4.0				

- 特殊サイズも注文により製作いたします。Special size is available upon request.
- ヘッドマスターアーバは、P22,23をご参照ください。See P22,23 for Head master arbor.

